

SanStar Series SSi and SSO Mixers

SANITARY MIXERS



A World Leader In Industrial Mixing Since 1923. Lightnin has 90 years of unrivaled experience in industrial mixing technology, process knowledge, and technological innovation. Lightnin enjoys a global reputation for durable, long-lasting mixers, agitators, aerators, and flocculators for fluid process systems. We offer a full spectrum of impeller designs for diverse applications. In addition, we offer a worldwide service network, mixer repair, gearbox repair, and replacement parts programs. Look to Lightnin for knowledge, technology and service excellence.

Based in Charlotte, North Carolina, SPX Corporation (NYSE: SPW) is a global Fortune 500 multi-industry manufacturing leader with over \$5 billion in annual revenue, operations in more than 35 countries and over 14,000 employees. The company's highly-specialized, engineered products and technologies are concentrated in Flow Technology and energy infrastructure. Many of SPX's innovative solutions are playing a role in helping to meet rising global demand for electricity and processed foods and beverages, particularly in emerging markets. The company's products include food processing systems for the food and beverage industry, critical Flow components for oil and gas processing, power transformers for utility companies, and cooling systems for power plants. For more information, please visit www.spx.com.

SanStar Series Stainless Steel Mixers

Designed to fit the needs of the biotechnology and pharmaceutical industries, the Stainless Steel In-line (SSi) and Stainless Steel Offset (SSO) are purpose built with your needs in mind. Suitable for buffer and media preparation, fermenters, bioreactors, product recovery, and bulk pharmaceutical processing, these products combine Lightnin's experience in mixer design and clean operations to bring you a machine of unmatched value!

DESIGNED FOR MIXING

Drawing on decades of experience in designing and manufacturing gearboxes specifically for mixer applications, the SSi and SSO feature robust machines that are made to last.

Features include:

- **All Stainless Steel Construction:** All housings are made of 300 series stainless steel with a polished surface finish for easier cleaning.
- **Stainless Steel Motors:** Using high quality stainless steel motors to ensure that every unit is up to the standards required for the bio/pharmaceutical industry.
- **Longer Shaft Lengths:** Designed to fit your tank, shafts as long as 4572mm (180") can be used without the need for any in tank support.
- **No Speed Block Out Ranges:** All gear reduced units are designed to run at variable speeds without the concern of a speed block out or avoidance range, allowing you to run at the speed you need to.
- **Large Range of Motor and Speed Options:** With powers ranging from 0.18kW (1/4 HP) up to 1.5 kW (2 HP) and nominal speeds from 1800 RPM all the way down to 84 RPM, there is a mixer to meet your process needs.
- **Clean Features Inside and Outside the Tank:** Designed for sanitary environments, these mixers provide features to make them easy to clean in place on your tank.
- **Multiple Mounting Options:** Because not all applications require the same mount or seal, the SSi and SSO come standard with your choice of mechanical seal, lip seal, or an open tank mount, along with a large variety of flanges to fit your tank.

Typical product applications

DESIGNED TO INDUSTRY STANDARDS

- Designed to comply with ASME BPE-2012.
- Full clean-in-place, sterilize-in-place (CIP/SIP) features.
- Single dry running mechanical seals available with or without sanitary purge gland. All seals come with food grade faces and USP Class VI elastomers.
- Both 50 Hz and 60 Hz motor options are available.
- Units are available standard with CE certification and can be designed for ATEX requirements.
- To demonstrate that current Good Manufacturing Practices (cGMP) guidelines have been met, every SanStar SSi and SSO mixer comes with our Quality Assurance Documentation (QAD) package.



A310/A510:

Low blade solidity hydrofoil, recommended for low viscosity blending and solid suspension applications.



A100:

Recommended for portable mixer applications where moderate pumping action with powder wetting is required.



A315:

High solidity hydrofoil design recommended for gas-liquid dispersion and mass transfer applications.



A320:

High viscosity hydrofoil design recommended for high viscosity blending applications.

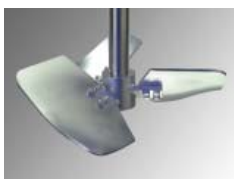

A340:

Recommended for up pumping multi-phase mixing applications with high gas rates.

With an all stainless steel construction and features designed to meet ASME BPE Standards, the SSi and SSO mixers can be used in a variety of sanitary mixing applications. And with Lightnin's unparalleled experience, every mixer comes with a process guarantee!

Pharmaceutical



Biotech



Personal Care



Beverage



Dairy



Prepared Foods



Cleaning Products



SSi - SanStar Series Inline Mixer

FEATURES

Combining Lightnin's expertise in building in-line gearboxes for industrial applications along with years of selling into the sanitary markets, the Lightnin SSi gives you a clean mixer with unparalleled experience. The SSi has a smaller footprint making it ideal for limited spaces.

- **All Stainless Steel Construction:** All housings are made of 300 series stainless steel with a polished surface finish for easier cleaning.
- **Stainless Steel Motors:** Standard IEC and NEMA frame motors (safe area and explosion proof) are available with stainless steel as an option.
- **Longer Shaft Lengths:** Shaft diameters from 19mm (.75") - 38mm (1.5") and lengths up to 3454mm (136").
- **No Speed Block Out Ranges in Gear Drives:** All gear reduced units (350 RPM and lower) are designed to run at variable speeds without the concern of a speed block out or avoidance range, allowing you to run at the speed you require.
- **Two Unit Sizes:** Two unit sizes are available with powers of 0.18kW (1/4HP) - 0.75kW (1HP) and output speeds of 155, 190, 230, 280, 350, 1000, 1200, 1500, and 1800 RPM.
- **Clean Features Inside and Outside the Tank:** Designed for sanitary environments, these mixers provide features to make them easy to clean in place on your tank.
- **Mix a Variety of Tank Sizes:** With a variety of powers, speeds, impellers, and shaft lengths, the SSi can be used to mix tanks ranging in volume from 100 liters (26 gals) - 2000 liters (528 gals).
- **Multiple Mounting Options:** Because not all applications require the same mount or seal, the SSi comes standard with your choice of mechanical seal, lip seal, or an open tank mount, along with an ANSI, DIN, or sanitary flange in a variety of sizes.



SSi - SanStar Series Inline Mixer

THEORY OF OPERATION:

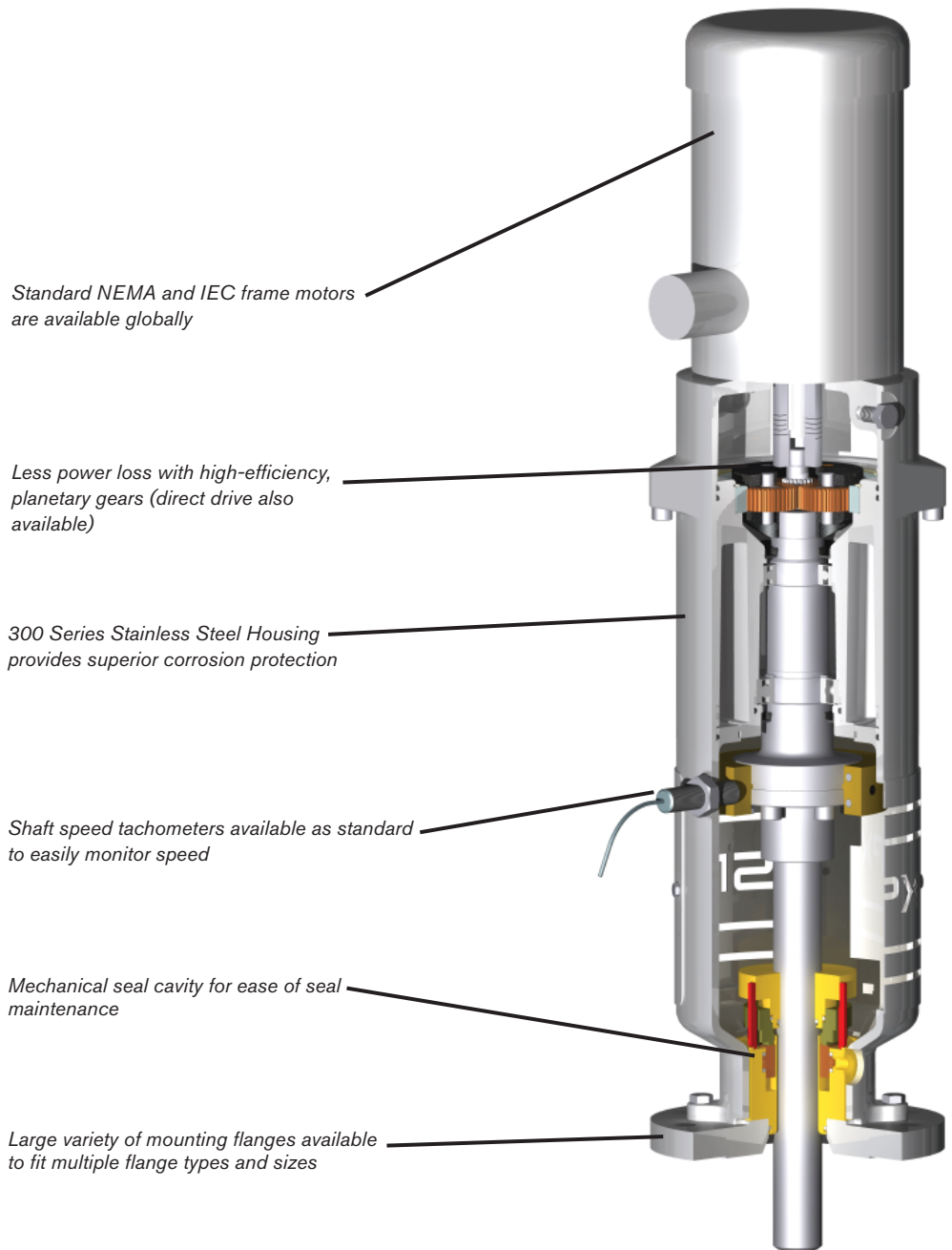

Lip Seal Mount



Open Tank Mount



SSO - SanStar Series Offset Mixer

FEATURES

Drawing on Lightnin's years of building offset gearboxes for industrial applications, the SSO brings a design to the sanitary markets that combines exceptionally long shaft lengths with easy maintenance and is ideal for larger tanks.

- **All Stainless Steel Construction:** All housings are made of 300 series stainless steel with a polished surface finish for easier cleaning.
- **Stainless Steel Motors:** Standard IEC and NEMA frame motors (safe area and explosion proof) are available with stainless steel as an option.
- **Longer Shaft Lengths:** Shaft diameters from 25mm (1") - 64mm (2.5") and lengths up to 4572mm (180").
- **No Speed Block Out Ranges:** All SSO units are designed to run at variable speeds without the concern of a speed block out or avoidance range, allowing you to run at the speed you require.
- **Two Unit Sizes:** Two unit sizes with powers of 0.18kW (1/4HP) - 1.5kW (2HP) and output speeds of 84, 100, 125, 155, 190, and 230 RPM.
- **Clean Features Inside and Outside the Tank:** Designed for sanitary environments, these mixers provide features to make them easy to clean in place on your tank.
- **Mix a Variety of Tank Sizes:** With a variety of powers, speeds, impellers, and shaft lengths, the SSO can be used to mix tanks ranging in volume from 400 liters (105 gals) - 20,000 liters (5280 gals).
- **Multiple Mounting Options:** Because not all applications require the same mount or seal, the SSO comes standard with your choice of mechanical seal, lip seal, or an open tank mount, along with an ANSI, DIN, or sanitary flange in a large variety of sizes



SSO - SanStar Series Offset Mixer

THEORY OF OPERATION:

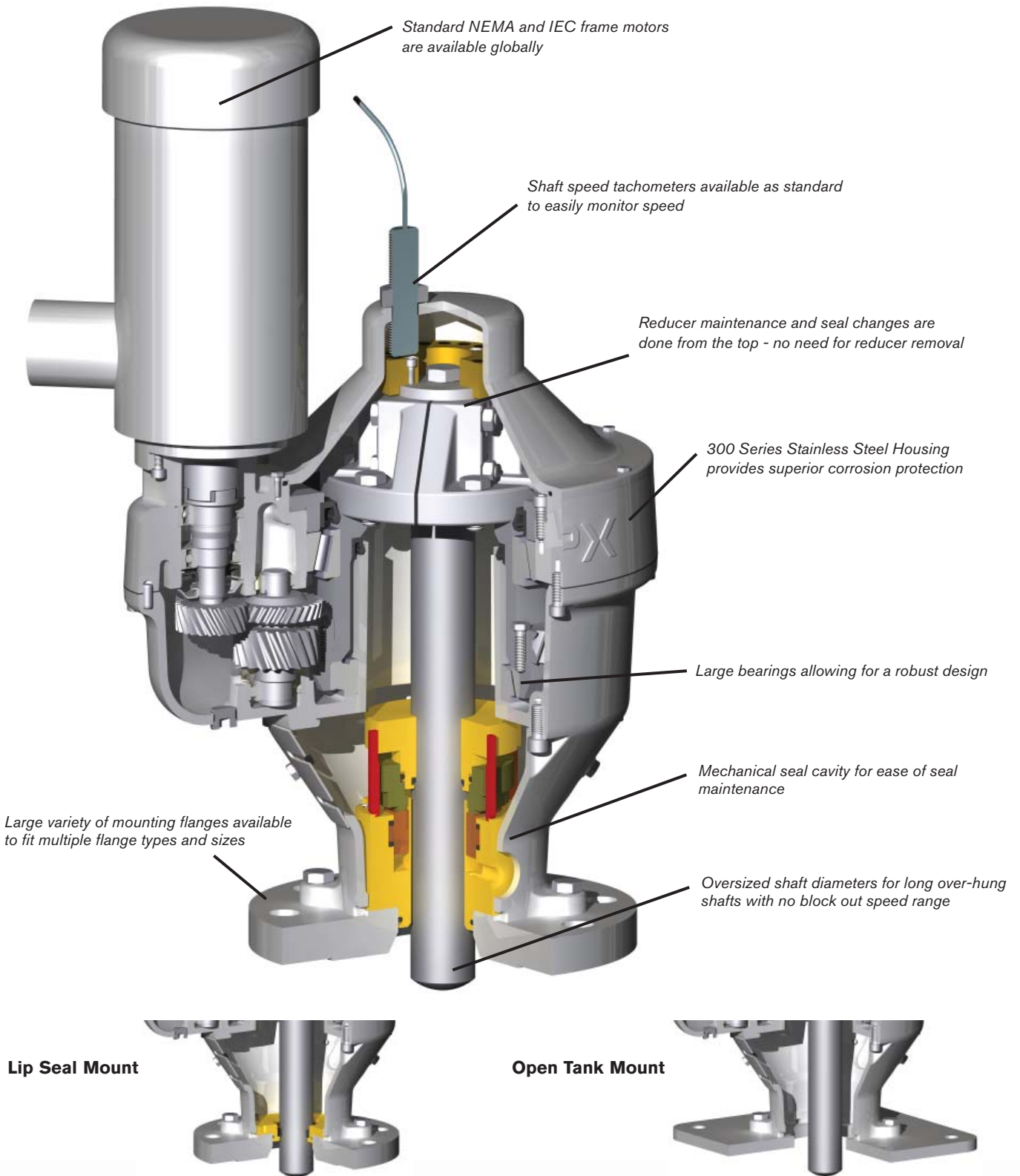



Global locations

USA

SPX GLOBAL HEADQUARTERS

13320 Ballantyne Corporate Place
Charlotte, NC 28277
United States of America
+1 704 752 4400

APAC

SPX ASIA PACIFIC

2F, Treasury Building
1568 Hua Shan Road
Shanghai 20000523
Peoples Republic of China
+86 21 2208 5888

EMEA

SPX EUROPE

Ocean House
Towers Business Park
Wilmslow Road
Manchester, M20 2LY England
+44 (0) 161 2491170

SPX FLOW TECHNOLOGY

135 Mt. Read Blvd.
Rochester, NY 14611
P: (888) 649-2378 (MIX-BEST), US and Canada) or +1 (585) 436-5550
F: (585) 436-5589
E: lightnin@spx.com • www.lightninmixers.com

For other Sales locations click
www.lightninmixers.com/contacts/where-to-buy/
or use your SmartPhone and the QR Code



SPX reserves the right to incorporate our latest design and material changes without notice or obligation.

Design features, materials of construction and dimensional data, as described in this bulletin, are provided for your information only and should not be relied upon unless confirmed in writing. Please contact your local sales representative for product availability in your region. For more information visit www.spx.com.

The green ">" is a trademark of SPX Corporation.

ISSUED 02/2014 B-955

COPYRIGHT © 2014 SPX Corporation