

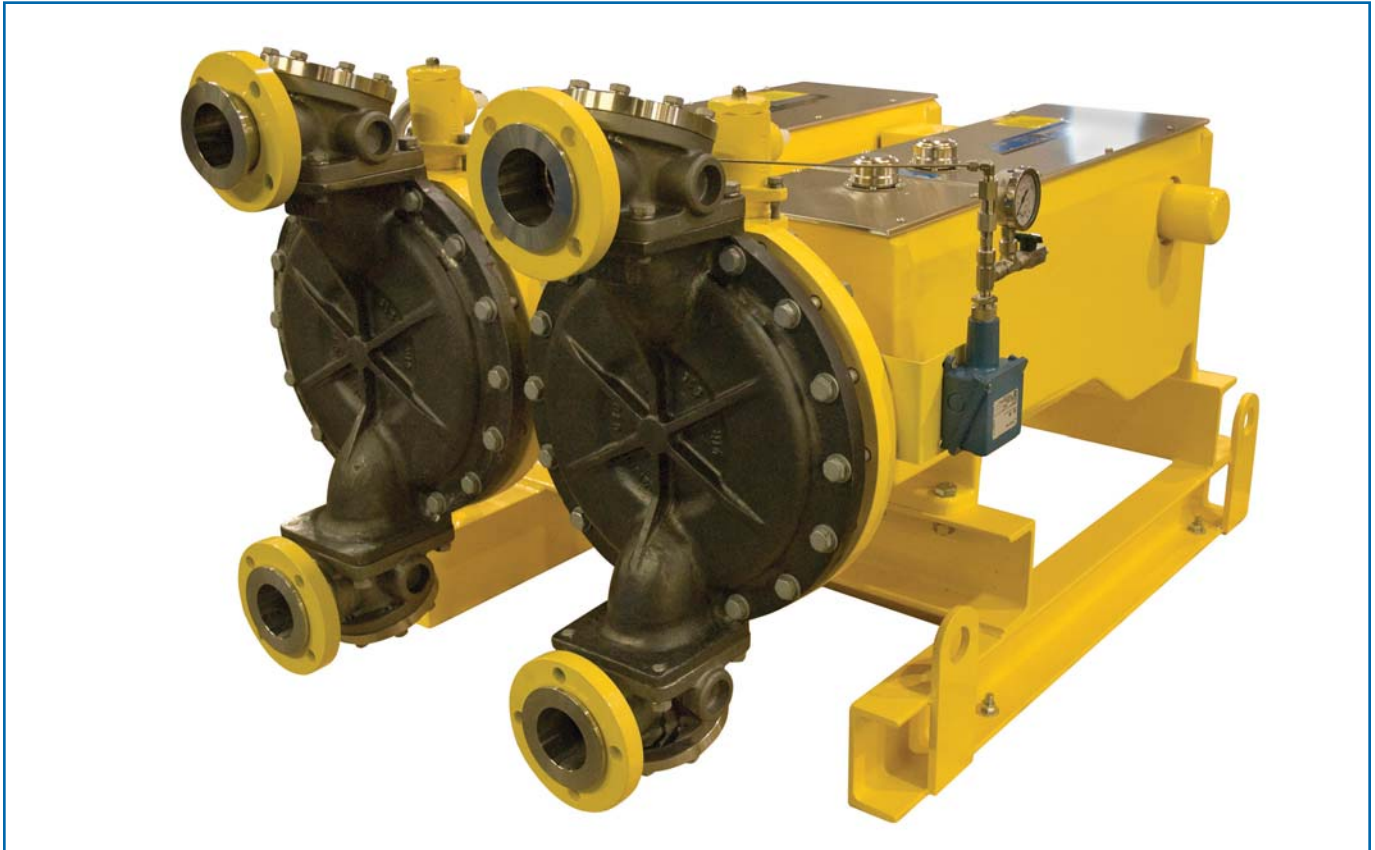

## MILROYAL<sup>®</sup> C PUMPS

### MILROYAL C DUPLEX WITH HPD LIQUID END



### GENERAL SPECIFICATIONS

#### **Drive**

Polar crank design — all moving parts submerged in oil. Front end scavenging—  
The plunger always set to top dead center on each stroke.

#### **Liquid Ends Available**

High Performance Diaphragm (HPD); Packed Plunger; Disc Diaphragm

#### **Accuracy**

±1.0% over 10:1 turndown ratio

#### **Maximum Performance Ratings (per head)**

2080 GPH (7873 l/h) @ 50 psig (3 bar) to 4 GPH (15 l/h) @ 10,000 psig (689 bar)

#### **Capacity Control**

Manual Micrometer standard; Electronic, pneumatic, or variable speed optional

#### **Multiplexing**

Up to 6 pumps driven by one motor. Limited to a maximum of 25 HP. Consult Applications  
Engineering concerning capabilities for a specific application.

#### **Approximate Shipping Weight.** (Simplex)

850–1400 lbs. (386–635 kg), depending upon liquid end selected



**HIGH PERFORMANCE DIAPHRAGM (HPD) LIQUID END PERFORMANCE**

*Typical performance based on 1725 RPM, 3 Phase, 60 Hz motor. Derate flow rates for all other RPM speeds.*

Plunger Dia.	Gear Ratio Code	SPM @ 1725 RPM	Maximum Capacity*		Maximum Discharge Pressure*									
					1 HP (0.75 kW)		1 1/4 HP (1.1 kW)		2 HP (1.5 kW)		3 HP (2.2 kW)		5 HP (4 kW)	
			GPH	L/H	PSIG	BAR	PSIG	BAR	PSIG	BAR	PSIG	BAR	PSIG	BAR
1" (25 mm)	8K	43	23	87	745	51	1545	107	2235	154	3025	209	—	—
	8J	71	38	143	465	32	1000	69	1550	107	2635	182	3025	209
	8H	85	46	174	315	22	770	53	1240	85	2150	148	3025	209
	8G	113	61	230	240	17	580	40	935	64	1620	112	2900	200
	8F	140	76	287	165	11	510	35	855	59	1520	105	2800	193
1 1/4" (32 mm)	8K	43	37	140	480	33	950	66	1420	98	2060	142	—	—
	8J	71	60	227	295	20	640	44	1000	69	1680	116	1930	133
	8H	85	72	272	200	14	490	34	790	54	1370	94	1930	133
	8G	113	97	367	150	10	370	26	590	41	1030	71	1900	131
	8F	140	120	454	110	8	325	22	545	38	970	67	1840	127
1 1/2" (38 mm)	8K	43	53	200	335	23	660	46	990	68	1350	93	—	—
	8J	71	88	333	205	14	445	31	695	48	1170	81	1350	93
	8H	85	105	397	140	10	345	24	550	38	950	66	1350	93
	8G	113	140	529	105	7	260	18	415	29	720	50	1300	90
	8F	140	173	654	75	5	230	16	380	26	675	47	1280	88
2" (51 mm)	8K	43	97	367	190	13	370	26	560	39	745	51	—	—
	8J	71	151	571	115	8	250	17	390	27	660	46	745	51
	8H	85	181	685	80	6	190	13	310	21	540	37	745	51
	8G	113	240	908	60	4	145	10	235	16	400	28	745	51
	8F	140	299	1131	40	3	130	9	215	15	380	26	740	51
2 1/2" (64 mm)	8K	43	145	548	120	8	240	17	350	24	500	34	—	—
	8J	71	240	908	70	5	160	11	250	17	420	29	470	32
	8H	85	288	1090	50	3	120	8	200	14	340	23	470	32
	8G	113	383	1449	40	3	90	6	150	10	260	18	380	26
	8F	140	475	1797	—	—	75	5	122	8	211	15	350	24
3 1/2" (89 mm)	8K	43	297	1124	60	4	120	8	185	13	235	16	—	—
	8J	71	490	1854	—	—	80	6	125	9	220	15	235	16
	8H	85	587	2221	—	—	60	4	100	7	175	12	220	15
	8G	113	780	2952	—	—	—	—	75	5	130	9	175	12
	8F	140	968	3663	—	—	—	—	65	4	100	7	170	12
5" (127 mm)	8K	43	573	2168	—	—	55	4	90	6	105	7	—	—
	8J	71	947	3584	—	—	35	2	60	4	95	7	105	7
	8H	85	1132	4284	—	—	—	—	45	3	85	6	105	7
	8G	113	1500	5677	—	—	—	—	35	2	65	4	80	6
	8F†	116	1545	5847	—	—	—	—	—	—	60	4	70	5
5 3/4" (146 mm)	8K	43	770	2914	—	—	50	3	65	4	—	—	—	—
	8J	71	1270	4807	—	—	35	2	55	4	65	4	—	—
	8H	85	1520	5753	—	—	—	—	40	3	55	4	65	4
	8G	113	2025	7664	—	—	—	—	—	—	40	3	50	3
	8F‡	116	2080	7872	—	—	—	—	—	—	40	3	50	3

Capacities listed are for discharge pressures up to 200 PSIG (14 Bar).  
Capacity will decrease 0.8% for each 100 PSIG (7 Bar) over 200 PSIG (14 Bar).

**NOTES:**

\* Plastic Liquid Ends are limited to 150 PSIG (10 Bar) @ 68°F (20°C) and are linearly derated to 65 PSI (4 Bar) @ 140°F (60°C).

† Derate capacities 5% when applying a diaphragm rupture detection system.

‡ These gear ratios are limited to 1450 RPM maximum. SPM and pump capacity noted is based on 1450 RPM motor.



### HPD LIQUID END DIMENSIONS

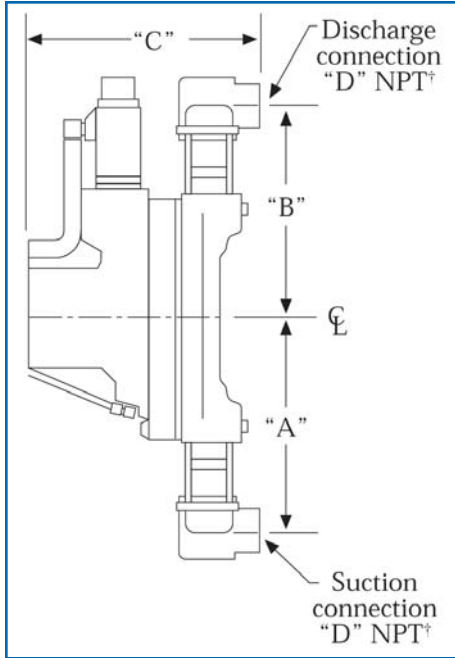

For exact dimensions, request a certified drawing

Material	Plunger Diameter		A‡		B‡		C*		D
	in.	mm	in.	mm	in.	mm	in.	mm	in.
Metal	1"	25	5 <sup>7</sup> / <sub>32</sub> "	133	5 <sup>7</sup> / <sub>32</sub> "	133	7 <sup>3</sup> / <sub>4</sub> "	197	1/2"
	1 <sup>1</sup> / <sub>4</sub> "	32	7 <sup>1</sup> / <sub>16</sub> "	179	7 <sup>1</sup> / <sub>16</sub> "	179	9 <sup>13</sup> / <sub>16</sub> "	249	1"
	1 <sup>1</sup> / <sub>2</sub> "	38	7 <sup>17</sup> / <sub>32</sub> "	191	7 <sup>17</sup> / <sub>32</sub> "	191	9 <sup>13</sup> / <sub>16</sub> "	249	1"
	2"	51	7 <sup>17</sup> / <sub>32</sub> "	191	7 <sup>17</sup> / <sub>32</sub> "	191	9 <sup>13</sup> / <sub>16</sub> "	249	1"
	2 <sup>1</sup> / <sub>2</sub> "	64	10 <sup>1</sup> / <sub>8</sub> "	257	10 <sup>1</sup> / <sub>8</sub> "	257	12 <sup>5</sup> / <sub>16</sub> "	313	1 <sup>1</sup> / <sub>2</sub> "
	3 <sup>1</sup> / <sub>2</sub> "	89	10 <sup>1</sup> / <sub>8</sub> "	257	10 <sup>1</sup> / <sub>8</sub> "	257	12 <sup>5</sup> / <sub>16</sub> "	313	1 <sup>1</sup> / <sub>2</sub> "
	5"	127	12 <sup>3</sup> / <sub>8</sub> "	314	12 <sup>3</sup> / <sub>8</sub> "	314	16 <sup>7</sup> / <sub>8</sub> "	429	—
Plastic	5 <sup>3</sup> / <sub>4</sub> "	146	12 <sup>3</sup> / <sub>8</sub> "	314	12 <sup>3</sup> / <sub>8</sub> "	314	16 <sup>7</sup> / <sub>8</sub> "	429	—
	2 <sup>1</sup> / <sub>2</sub> "	64	13"	330	13"	330	12"	305	1 <sup>1</sup> / <sub>2</sub> "
	3 <sup>1</sup> / <sub>2</sub> "	89	13"	330	13"	330	12"	305	1 <sup>1</sup> / <sub>2</sub> "
	5"	127	18 <sup>1</sup> / <sub>2</sub> "	470	14"	356	13 <sup>7</sup> / <sub>8</sub> "	352	2 <sup>1</sup> / <sub>2</sub> "†
	5 <sup>3</sup> / <sub>4</sub> "	146	18 <sup>1</sup> / <sub>2</sub> "	470	14"	356	13 <sup>7</sup> / <sub>8</sub> "	352	2 <sup>1</sup> / <sub>2</sub> "†

**NOTES:**

- \* 3"-150 lb. ANSI raised face flange.
- † Suction and discharge connections are horizontal on metal and vertical on plastic, except on plastic 5" (127 mm) and 5<sup>3</sup>/<sub>4</sub>" (146 mm) plungers, where suction is horizontal and discharge is vertical.
- ‡ A & B dimensions are based on standard ball check configuration: metallic-single ball checks (single poppet on 5" (127 mm) and 5<sup>3</sup>/<sub>4</sub>" (146 mm)); plastic-double ball checks (single on 5" (127 mm) and 5<sup>3</sup>/<sub>4</sub>" (146 mm)).

MILROYAL C

### MAXIMUM ALLOWABLE SUCTION PRESSURE RANGE — HPD

Plunger Diameter		Standard		Mid Range		High Range		Maximum Range	
in.	mm	PSIG	Bar	PSIG	Bar	PSIG	Bar	PSIG	Bar
1"	25	100	7	—	—	—	—	—	—
1 <sup>1</sup> / <sub>4</sub> "	32	100	7	—	—	—	—	—	—
1 <sup>1</sup> / <sub>2</sub> "	38	85	6	100	7	—	—	—	—
2"	51	70	5	100	7	—	—	—	—
2 <sup>1</sup> / <sub>2</sub> "	64	50	3	70	5	100	7	—	—
3 <sup>1</sup> / <sub>2</sub> "	89	30	2	40	3	70	5	100	7
5"	127	12	1	17	1	28	2	65	4
5 <sup>3</sup> / <sub>4</sub> "	146	9	1	13	1	21	1	50	3



## HIGH PERFORMANCE DIAPHRAGM (HPD) LIQUID END MODEL CODE

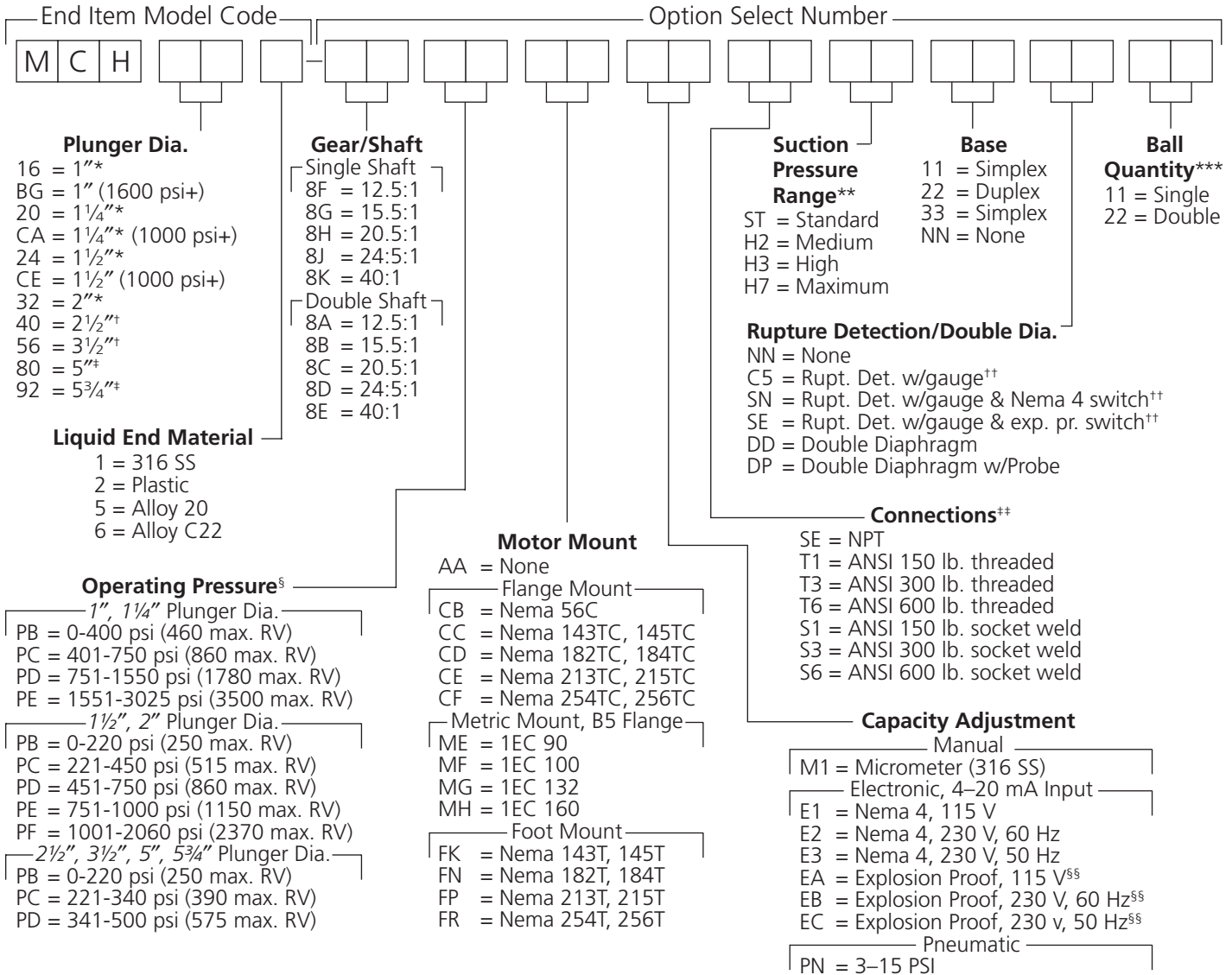

### NOTES:

- \* Plunger codes 16, BG, 20, CA, 24, CE, & 32 are not available with plastic liquid ends (liquid end material code 2) since this capacity range is covered by the Milroyal B Series.
- † Plunger codes 40 & 56 are only available with double ball checks (ball quantity code 22) when ordered in plastic.
- ‡ Plunger codes 80 & 92 are only available with poppet valves on metallic pumps or single ball checks on plastic pumps (ball quantity code 11), and ANSI 150 lb. socket weld connections (connection code S1). Plunger codes 80 & 92 are not available in Alloy C22 (liquid end material code 6).
- § Operating pressure is the application system pressure. The internal relief valve is normally set 15% above the operating pressure. If an internal relief valve setting greater than 15% above the operating pressure range is required, select the operating pressure range that will accommodate the relief valve setting.
- \*\* Refer to the suction pressure table for maximum suction pressure vs. range.
- †† Options C5, SN, and SE are only available on metallic liquid ends.
- ‡‡ Flange sizes equal the NPT connection size as noted on the liquid end drawing.
- §§ Explosion proof electronic actuators are certified by Factory Mutual for Class I, Division I, Groups B, C, & D; Class II, Division I, Groups E, F, & G.
- \*\*\* Special ball check and seat materials are available for severe slurry service. Contact factory.



### DISC DIAPHRAGM LIQUID END PERFORMANCE

Typical performance based on 1725 RPM, 3 Phase, 60 Hz motor. Derate flow rates for all other RPM speeds.

Plunger Dia.	Gear Ratio Code	SPM @ 1725 RPM	Maximum Capacity*		Maximum Discharge Pressure*									
					1 HP (0.75 kW)		1 1/4 HP (1.1 kW)		2 HP (1.5 kW)		3 HP (2.2 kW)		5 HP (4 kW)	
					PSIG	BAR	PSIG	BAR	PSIG	BAR	PSIG	BAR	PSIG	BAR
5/8" (16 mm)	8K	43	8.2	31	2710	187	3500	241	—	—	—	—	—	—
	8J	71	13.7	51	1920	132	3500	241	3500	241	—	—	—	—
	8H	85	16.4	62	1210	83	2780	192	3500	241	—	—	—	—
	8G	113	21.8	82	910	63	2090	144	2850	197	3500	241	—	—
	8F	140	27.2	103	725	50	1840	127	2940	203	3500	241	—	—
7/8" (22 mm)	8K	43	16.8	63	1320	91	2550	176	3500	241	—	—	—	—
	8J	71	27.5	104	850	59	1750	121	2660	183	3500	241	—	—
	8H	85	33.2	125	570	39	1350	93	2110	145	3500	241	—	—
	8G	113	44.2	167	430	30	1010	70	1580	109	2720	188	3500	241
	8F	140	54.5	206	330	23	890	61	1440	99	2540	175	3500	241
1 1/8" (28 mm)	8K	43	28.5	107	775	53	1510	104	2260	156	2400	165	—	—
	8J	71	47	177	490	34	1030	71	1575	109	2360	163	2400	165
	8H	85	56	212	325	22	795	55	1250	86	2150	148	2400	165
	8G	113	74	280	240	17	590	41	940	65	1620	112	2400	165
	8F	140	93	352	180	12	515	36	845	58	1500	103	2400	165
1 1/2" (38 mm)	8K	43	50	189	420	29	845	58	1270	88	1350	93	—	—
	8J	71	84	317	260	18	570	39	885	61	1330	92	1350	93
	8H	85	101	382	160	11	430	30	690	48	1210	83	1350	93
	8G	113	135	511	120	8	325	22	520	36	910	63	1350	93
	8F	140	165	624	85	6	275	19	465	32	840	58	1350	93
2" (51 mm)	8K	43	90	340	220	15	450	31	725	50	745	51	—	—
	8J	71	150	567	130	9	300	21	475	33	730	50	745	51
	8H	85	179	677	80	6	225	16	370	26	660	46	745	51
	8G	113	238	900	60	4	170	12	280	19	495	34	745	51
	8F	140	295	1116	35	2	140	10	245	17	455	31	745	51
2 1/2" (64 mm)	8K	43	140	529	130	9	280	19	300	21	—	—	—	—
	8J	71	233	881	75	5	180	12	295	20	300	21	—	—
	8H	85	277	1048	40	3	135	9	225	16	300	21	—	—
	8G	113	368	1392	—	—	100	7	170	12	300	21	—	—
3 1/2" (89 mm)	8K	43	280	1059	—	—	130	9	210	14	—	—	—	—
	8J	71	471	1782	—	—	85	6	145	10	210	14	—	—
	8H	85	558	2112	—	—	55	4	105	7	200	14	210	14
	8G	113	742	2808	—	—	40	3	80	6	150	10	160	11

Capacities listed are for discharge pressures up to 1000 PSIG (69 Bar).  
Capacity will decrease 1.0% for each 100 PSIG (7 Bar) over 1000 PSIG (69 Bar).



**DISC DIAPHRAGM LIQUID END DIMENSIONS**

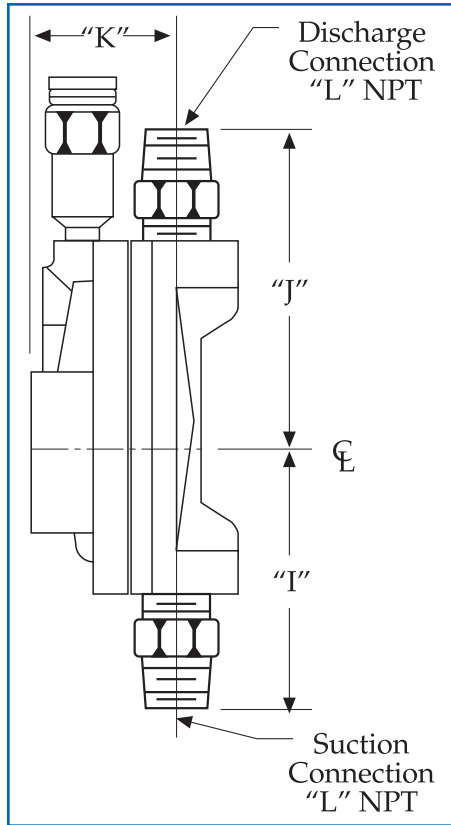

Material	Plunger Diameter		I		J		K		L
	in.	mm	in.	mm	in.	mm	in.	mm	in.
Metal	5/8"	16	7 1/8"	181	7 1/8"	181	5 1/2"	140	1 1/4"
	7/8"	22	7 1/8"	181	7 1/8"	181	5 5/8"	143	1 1/4"
	1 1/8"	28	8 1/16"	205	8 3/8"	213	5 5/8"	143	1 1/2"
	1 1/2"	38	10 5/8"	270	10 5/8"	270	6 3/16"	157	2 1/2"
	2"	51	11 1/16"	281	13 1/16"	332	6 1/2"	165	3"
	2 1/2"	64							
	3 1/2"	89							

**MILROYAL C**

**MAXIMUM ALLOWABLE SUCTION PRESSURE RANGE — DISC DIAPHRAGM**

Plunger Diameter		Maximum Range	
in.	mm	PSIG	Bar
5/8"	16	450	31
7/8"	22	250	17
1 1/8"	28	170	12
1 1/2"	38	110	8
2"	51	70	5
2 1/2"	64	50	3
3"	89	30	2



### MILROYAL C DISC DIAPHRAGM LIQUID END MODEL CODE

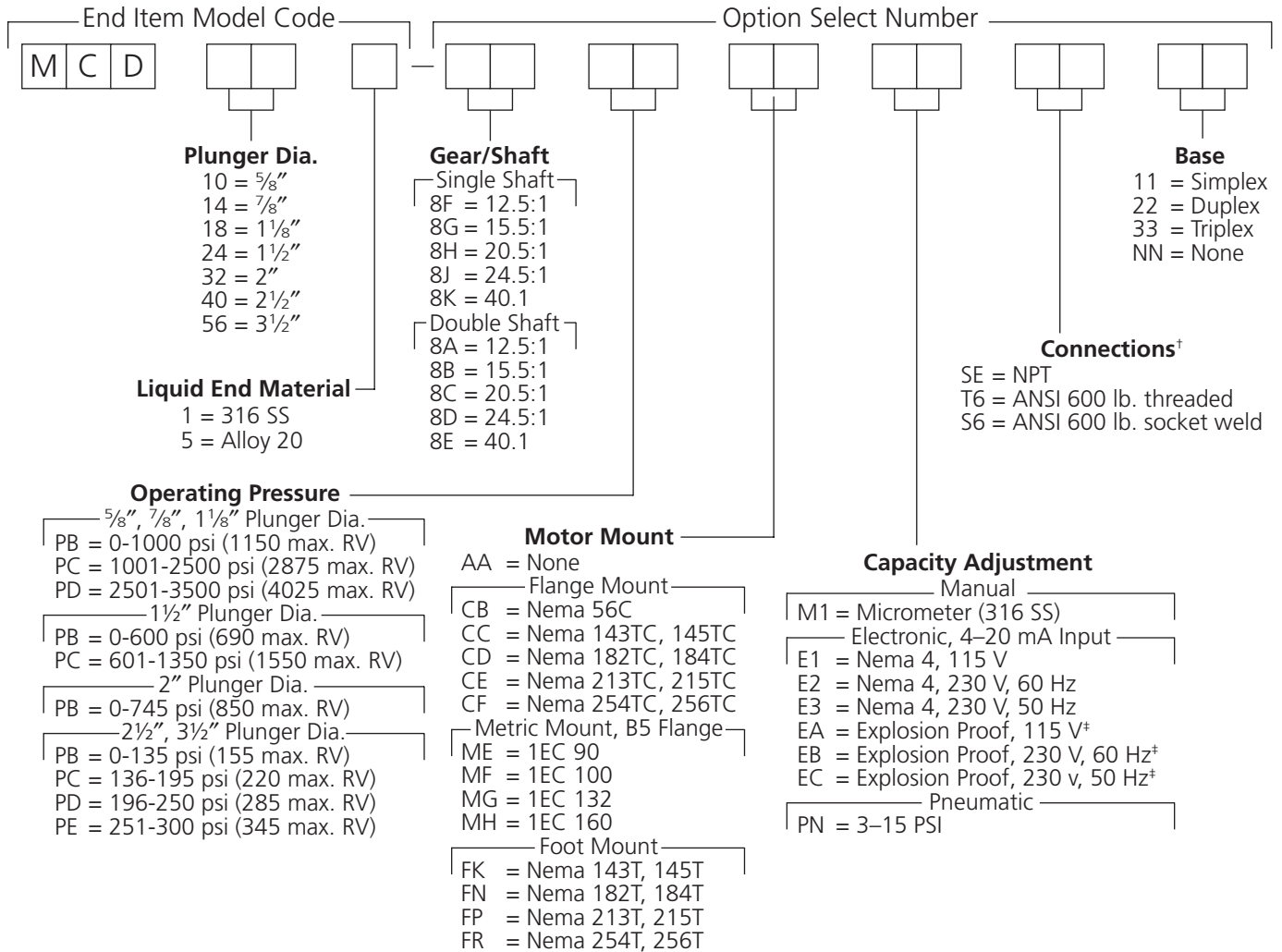

MILROYAL C

#### NOTES:

- \* Operating pressure is the application system pressure. The internal relief valve is normally set 15% above the operating pressure. If an internal relief valve setting greater than 15% above the operating pressure range is required, select the operating pressure range that will accommodate the relief valve setting.
- † Flange sizes equal the NPT connection size as noted on the liquid end drawing.
- ‡ Explosion proof electronic actuators are certified by Factory Mutual for Class I, Division I, Groups B, C, & D; Class II, Division I, Groups E, F, & G.



**PACKED PLUNGER LIQUID END PERFORMANCE**

*Typical performance based on 1725 RPM, 3 Phase, 60 Hz motor. Derate flow rates for all other RPM speeds.*

Plunger Dia.	Gear Ratio Code	SPM @ 1725 RPM	Maximum Capacity*		Maximum Discharge Pressure*									
					1 HP (0.75 kW)		1 1/4 HP (1.1 kW)		2 HP (1.5 kW)		3 HP (2.2 kW)		5 HP (4 kW)	
					GPH	L/H	PSIG	BAR	PSIG	BAR	PSIG	BAR	PSIG	BAR
7/16" (11 mm)	8K	43	4.0	15	5500	379	7500	517	10000	689	—	—	—	—
	8J	71	6.7	25	3630	250	7400	510	7500	517	10000	689	—	—
	8H	85	7.9	29	2875	198	5680	392	7500	517	10000	689	—	—
	8G	113	10.5	39	2150	148	4275	295	6100	421	7500	517	10000	689
	8F	140	13.2	50	1545	107	4000	276	5920	408	7500	517	10000	689
5/8" (16 mm)	8K	43	8.6	32	2700	186	5190	358	7500	517	—	—	—	—
	8J	71	14.5	54	1920	132	3545	244	5370	370	7390	510	7500	517
	8H	85	17.2	65	1210	83	2780	192	4300	296	7300	503	7500	517
	8G	113	22.8	86	910	63	2090	144	3230	223	5495	379	7500	517
	8F	140	28.7	108	725	50	1840	127	2940	203	5190	358	7500	517
7/8" (22 mm)	8K	43	17.7	67	1320	91	2550	176	3800	262	4050	279	—	—
	8J	71	29.1	110	850	59	1750	121	2660	183	3990	275	4050	279
	8H	85	35.0	132	570	39	1350	93	2110	145	3625	250	4050	279
	8G	113	46.5	176	430	30	1015	70	1585	109	2725	188	4050	279
	8F	140	57.4	217	330	23	890	61	1400	97	2540	175	4050	279
1 1/8" (29 mm)	8K	43	29.9	113	775	53	1510	104	2260	156	2415	167	—	—
	8J	71	49.7	188	490	34	1030	71	1575	109	2380	164	2415	167
	8H	85	59.1	223	325	22	795	55	1250	86	2150	148	2415	167
	8G	113	78.5	297	240	17	595	41	940	65	1620	112	2415	167
	8F	140	97.8	370	180	12	515	36	845	58	1500	103	2415	167
1 1/2" (38 mm)	8K	43	53.0	200	420	29	845	58	1270	88	1360	94	—	—
	8J	71	88.0	333	260	18	570	39	885	61	1340	92	1360	94
	8H	85	105	397	160	11	430	30	690	48	1210	83	1360	94
	8G	113	140	529	120	8	325	22	520	36	910	63	1360	94
	8F	140	173	654	85	6	275	19	465	32	840	58	1360	94
2" (51 mm)	8K	43	94	355	220	15	450	31	725	50	745	51	—	—
	8J	71	156	590	130	9	300	21	475	33	660	46	745	51
	8H	85	186	704	80	6	225	16	370	26	660	46	745	51
	8G	113	248	938	60	4	170	12	280	29	495	34	745	51
	8F	140	308	1165	35	2	140	10	245	17	455	31	745	51
2 1/2" (64 mm)	8K	43	146	552	130	9	280	19	435	30	470	32	—	—
	8J	71	244	923	75	5	185	13	350	24	460	32	470	32
	8H	85	292	1105	40	3	135	9	225	16	415	29	470	32
	8G	113	389	1472	—	—	100	7	170	12	310	21	385	27
3 1/2" (89 mm)	8K	43	285	1078	—	—	130	9	210	14	230	16	—	—
	8J	71	475	1797	—	—	85	6	165	11	225	16	230	16
	8H	85	565	2138	—	—	55	4	105	7	200	14	230	16
	8G	113	755	2857	—	—	40	3	80	6	150	10	190	13
4 7/16" (113 mm)	8K	43	465	1760	—	—	80	6	120	8	140	10	—	—
	8J	71	770	2914	—	—	45	3	80	6	135	9	140	10
	8H	85	923	3493	—	—	—	—	55	4	115	8	140	10
	8G	113	1225	4636	—	—	—	—	—	—	85	6	115	8

Capacities listed are for discharge pressures up to 2000 PSIG (137 Bar).  
Capacities may vary at pressures greater than 2000 PSI (137 Bar) based on packing selection.





### PACKED PLUNGER LIQUID END DIMENSIONS

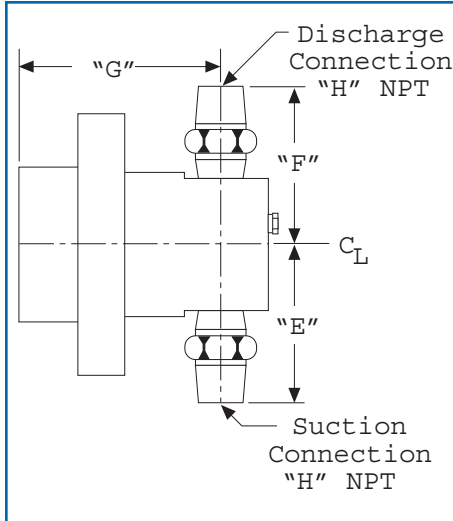

Material	Plunger Diameter		E		F		G		H
	in.	mm	in.	mm	in.	mm	in.	mm	in.
Metal Only	7/16"	11							
	5/8"	16	4 1/2"	114	4 1/2"	114	4 5/16"	110	3/4"
	7/8"	22							
	1 1/8"	29	5 9/16"	141	5 9/16"	141	4 5/16"	110	1 1/4"
	1 1/2"	38	5"	127	5"	127	4 7/16"	113	1 1/2"
	2"	51	5 5/8"	143	5 5/8"	143	5 1/8"	130	1 1/2"
	2 1/2"	64	7 3/8"	187	7 3/8"	187	7"	178	2 1/2"
	3 1/2"	89	8 3/4"	222	8 3/4"	222	4 3/4"	121	3"
	4 7/16"	113	8 1/8"	206	8 1/8"	206	4 13/16"	122	3"

### MAXIMUM ALLOWABLE SUCTION PRESSURE RANGE — PACKED PLUNGER

Plunger Diameter		Standard		Mid Range		High Range		Maximum Range	
in.	mm	PSIG	Bar	PSIG	Bar	PSIG	Bar	PSIG	Bar
7/16"	11	850	59	1510	104	2950	203	—	—
5/8"	16	450	31	780	54	1500	103	3800	262
7/8"	22	250	17	420	29	780	54	2000	138
1 1/8"	29	170	12	250	17	490	34	1200	83
1 1/2"	38	110	8	165	11	290	20	690	48
2"	51	70	5	100	7	170	12	395	27
2 1/2"	64	50	3	70	5	115	8	260	18
3 1/2"	89	30	2	40	3	70	5	140	10
4 7/16"	113	25	2	30	2	40	3	85	6



## PACKED PLUNGER LIQUID END MODEL CODE

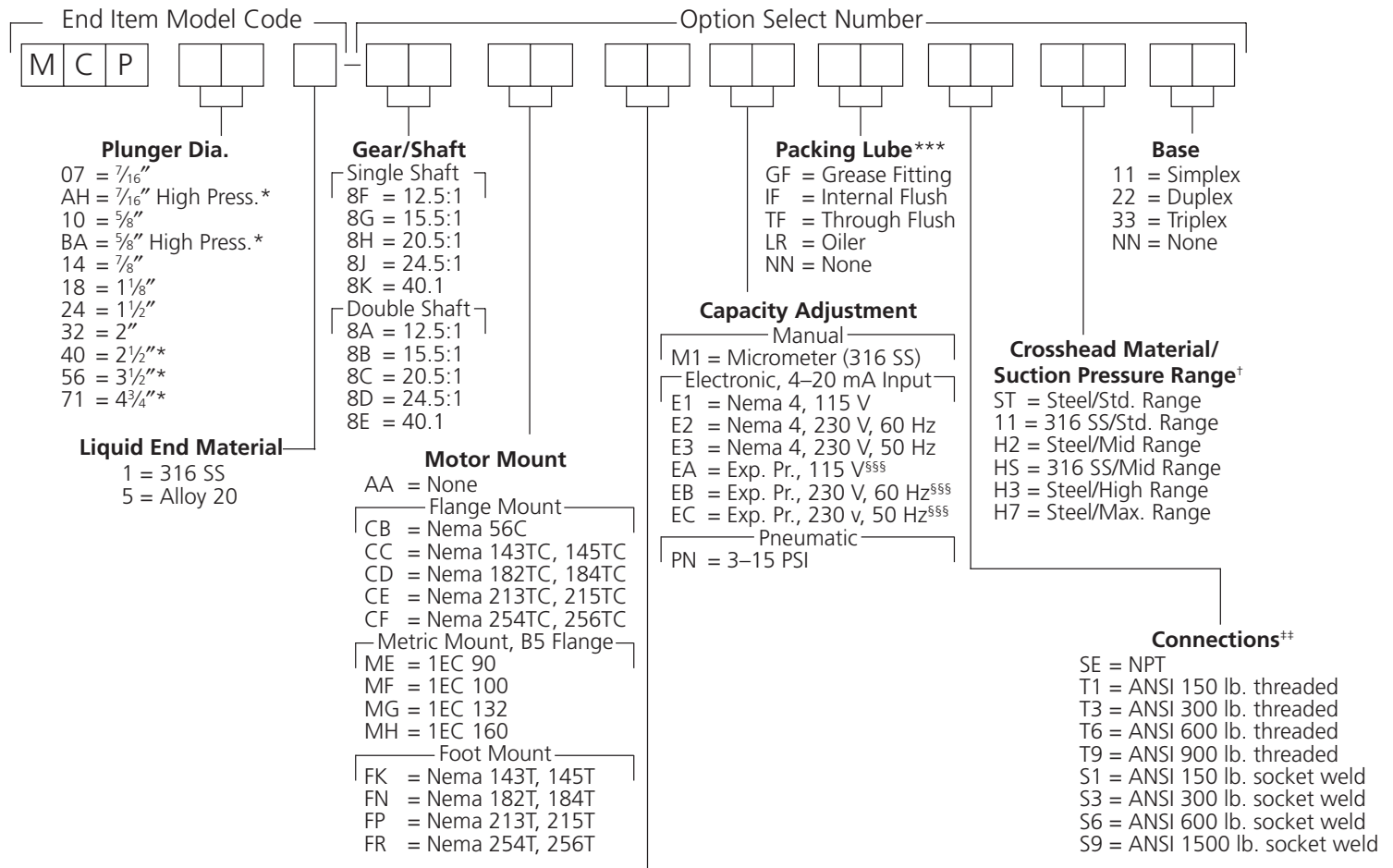

### Packing/Plunger Material

Code	Description	Type	Plunger range	PSI Range*	Plunger Materials	Oiler Suggested?
TM	Teflon Braid 5022 AFP	Compression-User adjust required	7/16" to 1 1/8"	0 to 1500	316ss or A 20 (Same as Liquid end)	No
BC	Teflon Braid 5022 AFP		1 1/8" to 4 7/16"		Ceramic	
NM	Nitrile Fabric	V-Ring	4 7/16"	0 to 10,000*	316 ss	Yes
NR	Nitrile Fabric				Ceramic	
TR	Teflon	Spring load self adjust	7/16" to 1 1/8"	0 to 10,000*	Ceramic	Yes

### NOTES:

- \* Plunger Diameter Codes BA, AH, 24, 32, 40, 56 & 71 are available in 316 SS only. Other liquid end materials can be quoted by the Milton Roy Application Engineering Department. High pressure plunger diameter codes are for applications requiring pressures over 5000 psi.
- \*\* Packing code NM is a standard option for 316 SS liquid ends with plunger diameters of 1 1/2" and larger.
- \*\*\* Select packing lube GF with packing codes TM & NM. Contact Applications Engineering for other packing lube selection.
- † Refer to suction pressure table for suction pressure versus range.
- †† Flange sizes equal the NPT connection size as noted on the liquid end drawing.
- ‡ Alloy 20 liquid ends are available standard with packing code TM. Contact applications engineering for other packings or plunger materials with Alloy 20 liquid ends.
- ‡‡ The plunger material will automatically match the liquid end material when selecting packing/plunger material code TM.
- § Packing/plunger codes AL, TL, & VL are offered on 316 SS liquid ends with 7/16" through 1 1/8" plunger diameters. Contact Milton Roy applications engineering to apply to other plunger diameters or liquid end materials.
- §§ Packing/plunger codes AR, TR, & VR are offered on 316 SS liquid ends with 7/16" and 5/8" high pressure plunger diameters. Contact Milton Roy applications engineering to apply to other plunger diameters or liquid end materials.
- §§§ Explosion proof electronic actuators are certified by Factory Mutual for Class I, Division I, Groups B, C, & D; Class II, Division I, Groups E, F, & G.



### HPD MATERIALS OF CONSTRUCTION — WETTED PARTS

Materials of Construction	Diaphragm	Diaphragm Head	Port Connection	Ball Seat	Ball Check	Ball Guide
316 SS <sup>†</sup>	PTFE/Elastomer	316 SS CF-8M	316 SS CF-8M	316 SS	316 SS	316 SS CF-8M <sup>§</sup>
Alloy 20 <sup>†</sup>	PTFE/Elastomer	20Cb-3 CN-D7M <sup>**</sup>	20Cb-3 CN-7M <sup>**</sup>	20Cb-3	20Cb-3	20Cb-D3 CN-7M <sup>*</sup>
Plastic <sup>†</sup>	PTFE/Elastomer	PVC <sup>*</sup>	PVC	PVC	Ceramic <sup>†</sup>	PVC
Alloy C22 <sup>†</sup>	PTFE/Elastomer	Alloy C22 CX2MW <sup>††</sup>	Alloy C22 CX2MW <sup>††</sup>	Alloy C22	Alloy C22	Alloy C22 CX2MW <sup>††</sup>

#### NOTES:

- \* Polyethylene diaphragm heads on 5" (127 mm) and 5¾" (146 mm) plunger size.
- † PTFE single ball checks used on 5" (127 mm) and 5¾" (146 mm) plunger size.
- ‡ Temperature range for metallic versions is 10°F (–12°C) to 225°F (107°C). PTFE/FKM diaphragm option is required above 190°F (88°C). Temperature range for plastic versions is 10°F (–12°C) to 140°F (60°C).
- § CF-8M is the cast equivalent to wrought 316 SS.
- \*\* CN-7M is the cast equivalent to wrought 20Cb-3 SS.
- †† CX2MW is the cast equivalent to wrought Alloy 20.

### DISC DIAPHRAGM MATERIALS OF CONSTRUCTION — WETTED PARTS

Materials of Construction	Diaphragm Head	Cartridge Body	Seats	Balls	Limit Pins	Diaphragm	Contour Plate
316 SS <sup>*</sup>	316 SS CF-8M <sup>†</sup>	316 SS CF-8M <sup>†</sup>	316 SS	316 SS	316 SS	PTFE	316 SS CF-8M <sup>†</sup>
Alloy 20 <sup>*</sup>	20Cb-3 CN-7M <sup>‡</sup>	20Cb-3 CN-7M <sup>‡</sup>	Alloy 20	Alloy 20	Alloy 20	PTFE	20Cb-3 CN-7M <sup>‡</sup>

#### NOTES:

- \* Temperature range is 20°F (–7°C) to 250°F (121°C).
- † CF-8M is the cast equivalent to wrought 316 SS.
- ‡ CN-7M is the cast equivalent to wrought 20Cb-3 SS.

### PACKED PLUNGER MATERIALS OF CONSTRUCTION — WETTED PARTS

Liquid End Material	Plunger	Check Valve	Seat	Seat Seal	Ball	Lantern Ring/ Spacers	Packing Spring	Gland Cap
316 SS	316 SS (to 1500 psi)	316 SS CF-8M <sup>*</sup>	316 SS	PTFE	316 SS	316 SS CF-8M <sup>*</sup>	N/A	316 SS CF-8M <sup>*</sup>
	Colmonoy (to 5000 psi)	316 SS CF-8M <sup>*</sup>	316 SS	PTFE	316 SS	316 SS CF-8M <sup>*</sup>	316 SS	316 SS CF-8M <sup>*</sup>
	Carbide (to 10,000 psi)	316 SS CF-8M <sup>*</sup>	Hardened 13-8 Mo	PTFE	Carbide	316 SS CF-8M <sup>*</sup>	316 SS	316 SS CF-8M <sup>*</sup>
Alloy 20	20Cb-3 CN-7M <sup>†</sup>	20Cb-3 CN-7M <sup>†</sup>	20Cb-3	PTFE	N/A	20Cb-3 CN-7M <sup>†</sup>	N/A	20Cb-3 CN-7M <sup>†</sup>

#### NOTES:

- \* CF-8M is the cast equivalent to wrought 316 SS.
- † CN-7M is the cast equivalent to wrought 20Cb-3 SS.



## DRIVE DIMENSIONS

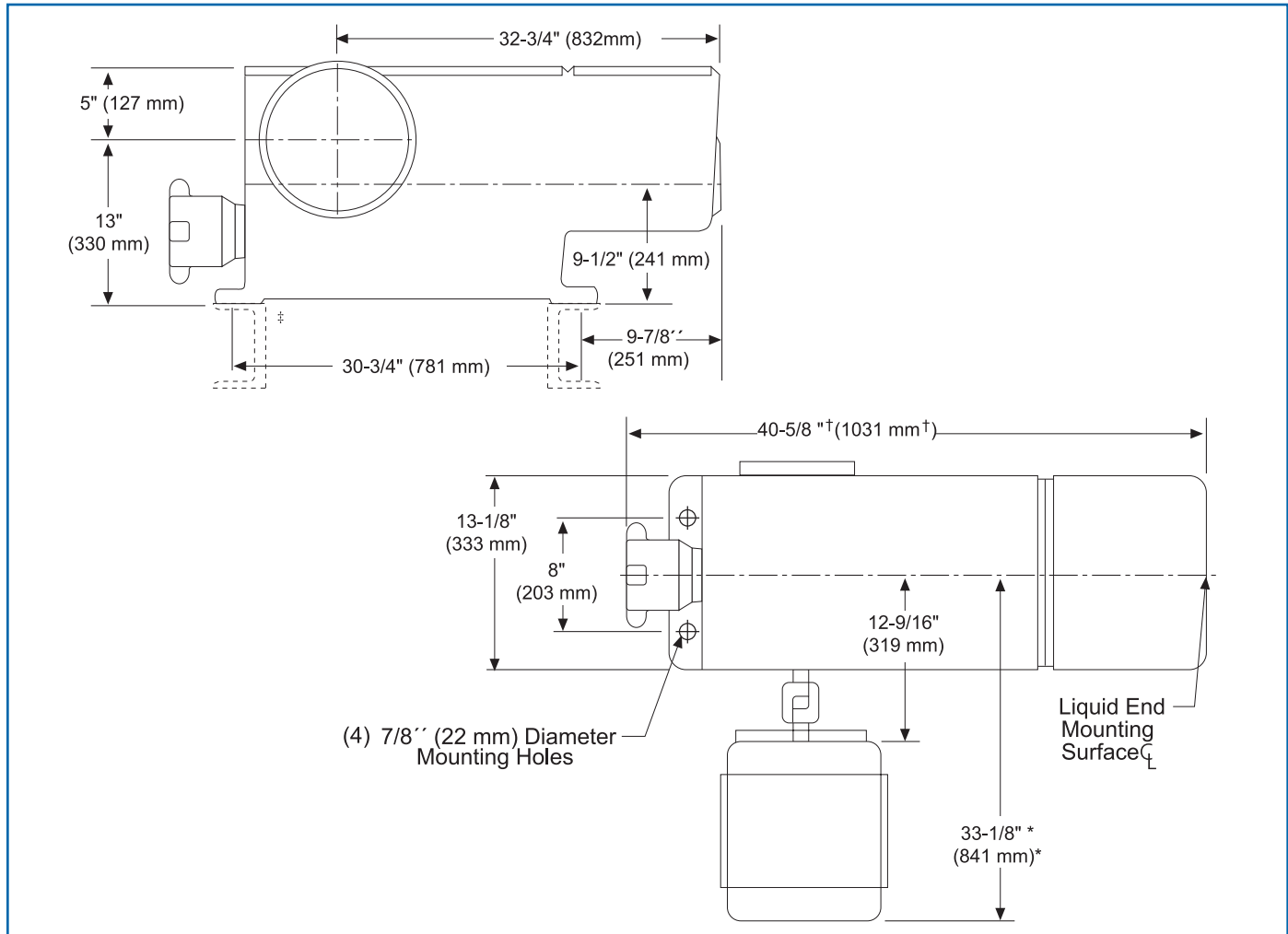

### NOTES:

- \* Dimension shown is for the largest available motor.
- ‡ Various bases are supplied with certain liquid ends and multiplex units. Consult factory for exact mounting dimensions.
- † 47" (1194 mm) is the dimension for manual stroke adjustment. For electronic stroke, overall length is 52" (1320 mm).

### AVAILABLE OPTIONS

- Double diaphragm
- Diaphragm rupture detection system
- Flanged connections
- Electronic capacity control
- Pneumatic capacity control
- Severe duty motors
- Variable speed drives
- Customer options available to fit your application

### ACCESSORIES

- Safety valves
- Back pressure valves
- Calibration columns
- Pulsation dampeners
- Tanks & standard systems
- Sludge traps

*All information contained herein subject to change without notice.*